

Rulebook

2015

**European
Garden
Pulling
Committee**



Chapter 0	Content	Page
Chapter 1	Competition rules	4
Chapter 2	General rules	8
	Dimensions	8
	Fire Extinguisher	8
	Seats	8
	Throttle	8
	Brakes	8
	Steering	8
	Exhaust pipes	8
	Fender	9
	Tow-hitch	9
	Stabilizer bars	9
	Drawbars	10
	Fuel lines	12
	Fuel	12
	Fuel cut	12
	Fuel tanks	12
	Emergency stop	12
	Ignition timer	13
	Starter	13
	Ventilation hoses	13
	Turbochargers	13
	Driveline	14
	Cardan joints	14
	Intercooler	15
	Cylinder head restraint system	15
	Reverse gear	15
	Vibration damper	15
Chapter 3	350kg Stock	16
Chapter 4	500kg Stock	17
Chapter 5	500kg Modified	18
Chapter 6	600kg Compact Diesel	20
Chapter 7	600kg Modified	23
Chapter 8	Roll Over Protection	26
Chapter 9	Operation of Contest	33

European Garden Pulling Committee

Pulling Rules for Europe

The European Garden Pulling Committee made this rulebook as a guide for you. We hope it will help to make pulling easy and fair for you as we discussed to standardize pulling rules and make Garden Pulling a safe and fair sport for all who are involved.

Whenever you need more information, please contact the EGPC Representatives of your national organization. All individual inquiries from pullers, promoters etc. must go through the respective national boards, which, if needed, will pass them on to the EGPC.

EGPC thanks to all national organizations for their help to make this rulebook.

Neither the EGPC Board nor the Tech & Safety Board nor any of their members can be made responsible for any damage or loss or technical or other kind or for any kind of human injury that may be caused by Garden Pulling sport.

No reproductions or reprints of this rulebook are permitted.

Copyright

European Garden Pulling Committee

www.gardenpulling.info

Chapter I

European Garden Pulling Committee Competition Rules

EGPC

The European Garden Pulling Committee is a coordinating organization in Europe. The EGPC is an association, whose objectives are to pursue and promote Garden Pulling in the widest sense in Europe.

The following organizations are affiliated to the EGPC:

Memberss	
BKTV <i>Belgische Kracht Tractoren Vereniging</i>	Belgium
BTPA <i>British Tractor Pullers Association</i>	Great Britain
DTP <i>Dansk Tractor Pulling</i>	Denmark
DTTO <i>Deutsche Trecker Treck Organisation</i>	Germany
FTPA <i>Finnish Tractor Pulling Organisation</i> <i>Suomen Traktoriurheiluliitto ry</i>	Finland
FTPF <i>Fédération du Tracteur Pulling Française</i>	France
ITPC <i>Irish Tractor Pulling Committee</i>	Ireland
LTPF <i>Letzebuerger Tractor Pulling Federatioun</i>	Luxembourg
NTPF <i>Norges Tractor Pulling Federation</i>	Norway
NTTO <i>Nederlandse Truck en Tractor Pulling</i> <i>Organisatie</i>	Netherlands
ÖTPO <i>Österreichische Tractor Pulling Organisation</i>	Austria
STPF <i>Svenska Tractor Pulling Förbundet</i>	Sweden
STPV <i>Schweizer Trecker Pulling Vereinigung</i>	Switzerland
Guestmembers	
Deport Public	Spain
FITP <i>Federazione Italiana Tractor Pulling</i>	Italy
MTPE <i>Magyar Tractor Pulling Egysület</i>	Hungary
PSTP <i>Polskie Stowarzyszenie Tractorpullingu</i>	Poland
RTPC <i>Russian Tractor Pulling Committee</i> <i>Российский Трактор Тяговая комите</i>	Russia
STPZ <i>Združenje Traktor Vleke Slovenije</i>	Slovenia

Safety

At every EGPC sanctioned event, safety is the name of the game. There are many different types of safety equipment required and this equipment will appear in many different areas of the vehicles. During a pull, safety is always in the front of every-one's mind. The end of track must be kept open all times. The EGPC as well as every one of its member organizations will refuse to operate any pull at which safety hazard is posed to any other person.

Safety is every-body's responsibility!

The promoter, pullers, spectators and EGPC officials must work together to ensure the safety of all persons involved.

Warranty disclaimer

The rules in this book are intended as guidelines for the motor sport Garden pulling and the rules relating to the safety of the equipment are the responsibility of each driver who participates Garden pulling under these rules.

No expressed or implied warranty of safety is intended nor may be inferred from the publication of these rules nor the compliance therewith. Nothing herein should be construed as a guarantee against injury or death to participants, bystanders or spectators.

Notice

Competitors are reminded and encouraged to contact the board of their organization if they plan to build a competition vehicle employing new or unique processes or techniques of are seeking to alter, change or modify existing competition vehicles, where such processes, techniques or modifications could raise questions of legality in items of rules regarding construction and / or safety.

Competition rules

A. Eligibility of contestants

1. All contestants participating in any Garden pulling contest sanctioned by an EGPC member must have a current competition membership. Contestants under 18 years of age must have a written allowance of its guardian (needed only once per season).

The following ages must be observed:

class	age
Stock 350kg	8 to 16 years
Stock 500kg	8 years or older
Modified 500kg	12 years or older
Compact Diesel 600kg	16 years or older
Modified 600kg	16 years or older

2. No driver, tractor nor any combination thereof shall participate or exhibit in a pull or pull in front of a non ETPC SIT approved sledge. The driver, all team members, the vehicle and all parts of the vehicle are disqualified for one year and ten days from this years infraction at all sanctioned EGPC or affiliated members pulls. The one year and ten days disqualification starts from the last violation day. In case the vehicle is to be sold, the disqualification must be mentioned to the new owner.

B. Vehicle registration

1. Registration means identifying your vehicle with a registration number for points calculation. All vehicles must be registered before competing.
2. The EGPC or affiliated member registration number must appear in a visible area of the vehicle.
3. A vehicle owner may sell the vehicle including the registration number and accumulated points. If points are sold with the vehicle, all points for all classes must be sold.
4. A puller can start competing with a new vehicle during a pulling season and keep his previous points from the season in question on condition that he uses the same name and registration number as with his old vehicle, and his old vehicle is not run anymore on that name and number.
5. On all above mentioned changes during the pulling year, to be calculated from the 1st of January, your organization board must be notified in writing after sale and before the vehicle is registered for the next pull.

C. Entry procedures

1. Each vehicle may enter only one class.
2. A puller can only receive points in the class where the vehicle is registered.

3. No mixing of classes.
4. Classes in a given session will be run in that session, but not necessarily in the scheduled order.
5. Once a puller has scratched from a class, he may not reenter.

D. Weight classes, Weighing and Drawbar measuring procedure

1. On each location there will be a designated area, set up by the track officials, as a tech area, where all vehicles will be routinely checked, the same applies for weighing and drawbar measuring.
2. All official weights include driver, vehicle with oil, water, fuel, and safety equipment, ready to compete. All drivers must weigh in with the pulling vehicle when it is officially weighed. No vehicles will be allowed past weight bridge that exceed class weight. No adding fuel or weights unless reweighed. Weighing out is at the discretion of the track officials.
3. After measuring the drawbar can not be altered. No air pressure to be added in tyres after drawbar is measured.
4. Drawbar can be re-measured after pull at the discretion of the track officials.

E. Track definition

1. A Gardenpulling track has to be at least:
 - Stock 350 and 500 length 50 meters.
 - Modified's and Compact Diesel 70 meters.
 - Width of the track 7 meters.
 - Physical barrier between track and audience.
2. At both sides of the track there has to be a free area of at least 8m wide.
3. At the end the track has to extend another 20m for roll-out.
4. At the beginning of the track there has to be enough room to setup a complete class with a clear view at the track.

Chapter 2

General Rules

A. **Dimensions**

1. The maximum length for Garden Pulling Tractors is 2000mm and 2440mm for 600kg Modified, measured from the centre of the rear axle to the furthestmost front point, including front weights, except towing hook.
2. The total maximum with is 1450mm for Compact Diesel Tractors and 1600mm for all other classes.

B. **Fire Extinguisher**

1. All Modified and Compact Diesel Tractors must be equipped with a minimum of one 1kg fire extinguisher fully charged, in working condition and within easy reach of the driver. (firesticks are also allowed)

C. **Seats**

1. All tractors must have a strong and rigid seat.
2. The seat must be securely fastened during the pull. The seat may not extend behind the rear wheels.
3. The seat must have a backrest with a minimum height of 100mm from the bottom of the seat.

D. **Throttle**

1. All tractors must be equipped with a dead-mans throttle. All throttles must work in forward direction and shall run at idle in the rearmost position.
2. All levers controlling injection or throttle valves must be fitted on each side with a neutral return spring.
3. All diesel engines must have a visible return spring on the linkage to the fuel injection pump lever.
4. No computers are allowed that controls any mechanical operations of the competing vehicle. RPM-limiters are excepted of this rule.
5. No automated or computer controlled traction control devices are allowed.
6. Computer controlled electronic fuel management systems are allowed.

E. **Brakes**

1. All vehicles must be equipped with properly functioning brakes acting on the rear axle.

F. **Steering**

1. All vehicles must have properly working steering capability.
2. The front wheels must run in the track of the rear wheels.

G. **Exhaust pipes**

1. All exhaust pipes must discharge vertically ($\pm 10^\circ$) and on turbocharged engines have a minimal wall thickness of 1.5mm steel up to the security cross.
2. The length must be at least 300mm from the exhaust port to the most far away point.

3. Tractors using the original silencers or a rear engine are exempt from this rules.
4. All exhaust pipes (an silencers) must be securely attached.
5. All turbocharged engines must have two M8 grade 8.8 bolts through exhaust pipe as close to the turbo as possible, bolts are allowed to be welded through pipe. Head of bolts must remain for inspection. Bolts to be installed 90° to each other, within max 20mm of each other.
6. After the security cross the exhaust may be made of other material.

H. **Fenders**

1. All tractors must be fitted with stable and firmly bolted fenders to protect the driver from the rear tyres, minimal vertical distance between tyre and fender is 20mm.

I. **Tow-eye**

1. All machines must have a tow-eye on the front with a hole of 25mm to 75mm.
2. The tow-eye has to strong enough to drag and lift the machine in the heaviest class it drives in.
3. The tow-eye may extend max. 150mm to the front and does not count in total length of the machine.

J. **Stabilizer bars**

1. Stabilizer are required on all tractors in all classes. The drawbar and the drawbar assembly must not be attached to the stabilizer bar in any way.
2. The device must have either a skid plate or wheels. The stabilizer pad must be at least 50mm x 75mm. Wheels must have a minimum diameter of 100mm an a minimum width of 25mm.
3. The stabilizer must extend at least 100mm and not more than 200mm to the rear tyre.
4. The maximum distance from the ground to the bottom edge of the skid plates of wheels may not exceed 150mm.
5. One skid plate or wheel has to be on each side of the tractor and have to be at least 200mm apart.
6. The stabilizer bar system must be strong enough to support the weight of the tractor ready-to-pull including the driver. Jacking up the pads that the tractor is completely off the ground will be a good test.
7. All tractors must have bumpers to prevent passing over the buckboard of the sled. They should have a height of at least 150mm measured vertically and the vertical piece of the bumper should be free of edges that can get stuck on the sledge.

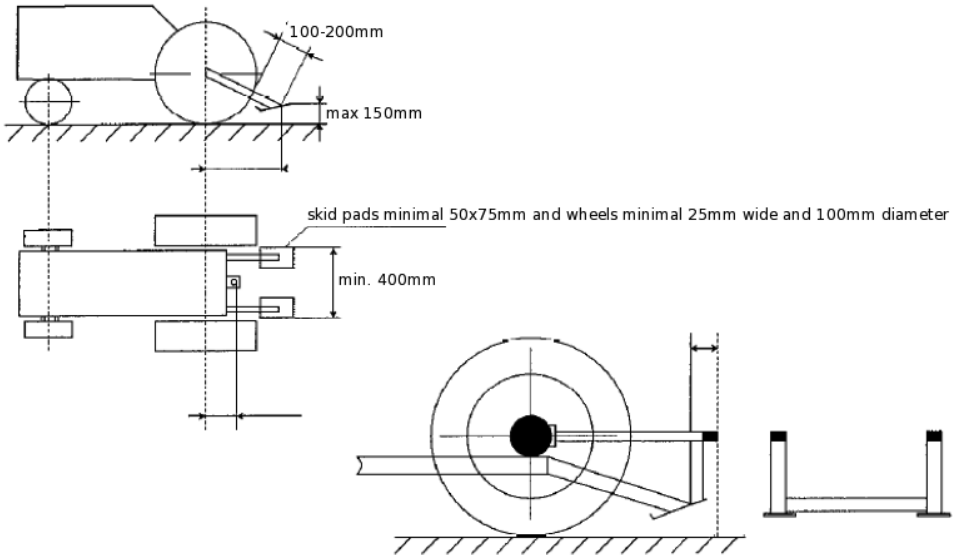

K. Drawbars

1. Drawbars shall be constructed so that in case of drawbar breakage the drawbar support does not pull from a top link of brace above the center-line of the rear axle of the vehicle.
2. A drawbar which can be made shorter than legal length is not permitted.
3. Drawbars must be rigid in all directions.
4. Drawbars must be parallel to the ground with a tolerance of $\pm 10^\circ$
5. Drawbars must be made from one piece of solid steel. No welding is allowed.
6. No part of the vehicle may contact sled, chain or hook during a pull or while being hooked or unhooked.
7. The area directly above the drawbar, must be free of all obstructions (including weights and stabilizer bars) for easy hooking and unhooking.
8. Drawbars and stabilizer bars may not be connected to each other.
9. The distance between the drawbar and the centre of the rear axle must not change during pull.
10. The distance between ground and hooking point must not exceed:
 - Stock 350kg, Stock 500kg and 500kg modified 270mm
 - Compact Diesels 350mm
 - 600kg modified 330mm
11. An area of 150mm wide and 300mm high immediately above the drawbar must be free of all obstructions (including weights and stabilizer bars) for easy hooking and unhooking.

12. Bolts for adjusting the height may not be placed more than 150mm from the hook-point.
13. Drawbars and hitching devices must be constructed of solid steel with a minimum of 400 N/mm² tensile strength (except Compact Diesel Tractors and 600kg Modified, here the minimum is 520 N/mm²). No welding on drawbars!
 - The minimum thickness of the drawbar on the hooking point (B) must be at least 12mm and not more than 18mm.
 - At any point the sectional area (A-A) and (C-C) has to be at least 600mm² including the mount point to the vehicle.
 - The diameter of the hole (F) must be between 40 and 50mm (Compact diesel and 600kg Modified 50 to 55mm).
 - Around the hooking point (hole) must be a cross sectional size of at least 200mm².
 - The fixing bolt of the drawbar must have a diameter of at least 12mm.
 - The cross section behind the mounting bolt(s) (G-G) has to be at least 350mm²
 - In case of axial fixing the sum of the area of the screws core diameters must be more than 144mm² (except Compact Diesel and 600kg modified Tractors).
 - The minimum length of the drawbar (E) measured from the centre of the rear wheels to the hooking point must not be shorter than 150mm.

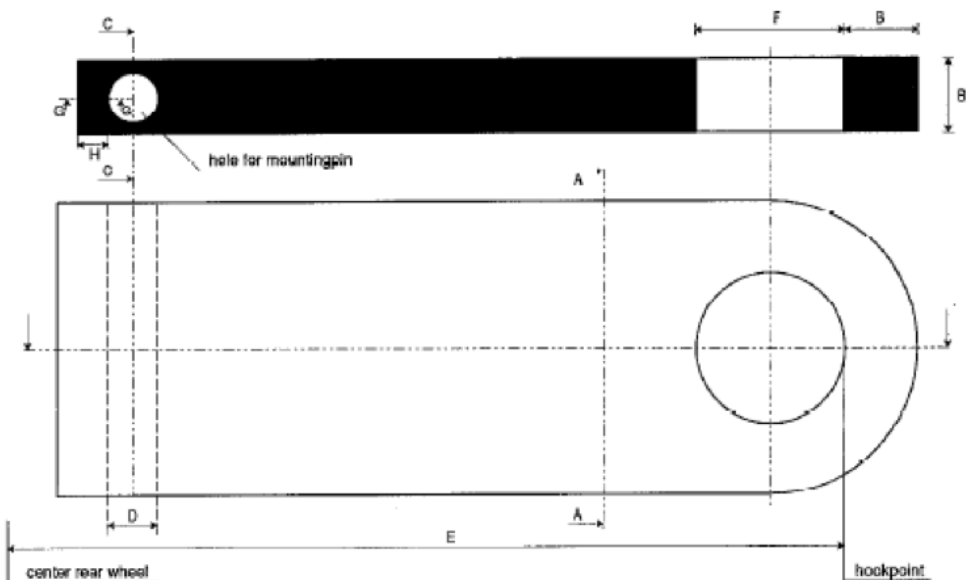

L. **Fuel tanks and Fuel lines**

1. Fuel tanks must be strong and steady and should not be mounted on the engine.
2. No fuel tanks, fuel pressure gauges, fuel pumps and/or fuel lines are allowed in the drivers compartment. If the fuel tank is located behind the driver, a firewall is highly recommended between the fuel line and driver. Minimum width of barrier equals to width of drivers seat.
3. All Tractors must have fuel lines that are either placed in protective channels or have a braided steel shroud.
4. All fuel tank ventilation's must lead away from engine and exhaust.

M. **Fuel**

1. **Legal fuels (only “pump” fuels allowed)**
 - Diesel
 - Petrol
 - Alcohol
2. **Illegal fuels**
 - All forms of nitro methane (including nitrous oxide and propylene oxide)
 - all forms of oxygen carriers or auxiliary chemicals
 - Pressurized Fuel

N. **Fuel cut**

1. All tractors must have a mechanical or fail-save electrical cut-off valve (fuel tap) on the low pressure side (except stock tractors).

O. **Emergency stop switch (kill switch) (other than stock tractors)**

1. all kill switches must be mounted independent of drawbar and/or stabilizer bars.
2. All tractors must be equipped with an automatic ignition kill switch and/or air/fuel shutoff in working order at all times. The kill switch device must also work in a situation where the electric circuit of the vehicle is interrupted. Every kill switch must generally work according to the Fail-Safe-Principle (No situation whatsoever may cause the kill switch going out of function). Track Officials and/or Tech Inspector have the option of checking kill switches as many times as they feel adequate at any event.
3. A kill switch on diesel engines must also stop the air supply immediately.

- diesel systems must have a spring-actuated air supply cut-off, which is activated by a bowden cable. (the air supply cut-off on turbo engines may have a hole in it off maximal 12mm.)
 - Systems which prevents building up pressure in the cylinder on Diesel engines will be accepted
4. The kill switch must be located on the rear centre of the tractor and must be accessible easily.
 5. The kill switch must be located 400mm (\pm 100mm) above the drawbar and within a range of 100mm left and right of the center.
 6. The break-away kill switches must have attached to them a ring a minimum diameter of 25mm. The thickness of the ring must be at least 3mm.
 7. The ring and the mounting of the kill switch have to be strong enough to withstand a release force of max. 15kg. All kill switches have to act in all directions. Kill switch activation force must be less then 15kg.
 8. The kill switch ring must be secured with a nylon tie wrap (3mm). If the kill switch is pulled and the nylon strap is broken and the presiding official inspects and finds the switch capable of operating properly under normal conditions, the vehicle will be allowed to re-pull immediately or drop six positions. The decision to drop must be made before vehicle leaves the track.

P. Ignition timer

1. If a tractor is equipped with an ignition with breaker points, the breaker points must be covered with a cover form plastic or metal to prevent fire hazard.

Q. Starter

1. Starter carts must have a protective cover over the battery terminals to prevent sparks.
2. All Modified and Compact Diesel tractors must be equipped with a green neutral gear light on the back of the machine (to show sledge crew it is safe to hook on) and a starter break circuit to make sure the engine can't be started when in gear.

R. Ventilation hoses

1. Engine ventilation hoses must be installed in front of the rear wheels. The openings of the hoses must be below the ends of the cylinder heads an must direct into the oil pan or into an external canister.

S. Turbochargers

1. All free mounted turbochargers are advised to be completed shrouded (360°), except for inlet- and exhaust pipes, with steel 2mm or thicker. The shielding must ensure that no wheels or other parts of the turbo can come out in case of a turbo explosion.
2. The shielding must extend 50mm beneath the turbocharger to the ground on both sides.

3. The width of the shielding must extend at least 50mm past the turbo. (axial)
4. The shielding must be mounted as close as possible to the turbo, at min 4 points.
5. The air intake of the turbo has to be shielded with at least a 1.5mm thick steel netting with at least 3mm bars and a maximum hole size of 5mm or a mesh made of at least 3mm wires and a maximum mesh size of 25x25mm if the intake is not shielded by the machines hood or grille or if that doesn't meet the shielding criteria. If the mesh is attached to the turbo shielding it has to be firmly mounted with at least 4 bolts.

T. **Driveline**

1. The driveline of Compact Diesel and all modified tractors must be shielded radially (360°). The shield must be made from steel with a wall thickness of at least 5mm or aluminium 6mm, the shielding should be round and maximum 50mm greater than the biggest part of the driveline.

U. **Cardan joints**

1. All cardan joints must be shielded radially (360°) with at least 5mm steel or 6mm aluminium. The minimum length of the shield must be at least 12 mm longer than the cardan joints.
2. The maximum deflection angle for universal joints is 10 °.
3. For Compact Diesel and 600kg modified no cardan joints, cross links or homokinetic couplings are allowed.

V. **Intercooler**

1. Pressurized intercoolers must be completely shrouded (360°), except inlet and outlet.
2. The cover must be at least 1.5 mm steel or equivalent aluminium.

W. **Cylinder head restraint system**

1. All turbocharged engines must have one steel cable totally surrounding the engine block and cylinder head.
2. The cable must be made of steel and must have a minimum diameter of 8mm.
3. The cable must be positioned between the first and second cylinder (from the front) and runs between the cylinder head and exhaust pipe.
4. The cable must have approximately 100mm of slack.
5. Cable ends must be connected together with D-Lock/Shackle.
6. All engines using a blower on the top of the engine must use blower restraints. The restraint system shall consist of four separate nylon straps (width 30mm) or steel cables (diameter 6mm).

X. **Reverse gear**

1. Vehicles with a reverse gear must have a white light on the back (min. 50x50mm) and at least an instrument panel light in face of the driver to indicate if tractor is in reverse.

Y. Vibration damper

1. Vibration damper must be mounted with a bolt in the crankshaft.
2. Vibration damper must be shielded 360° with 5mm steel or 6mm aluminium.

Chapter 3

350kg Stock

1. The tractor must have been produced commercially in standard and series and must have a cast engine block. Engine and frame must be original and must have the appearance of a garden tractor.
2. It is allowed to change the engine, but the engine power must not exceed 25HP, with a maximum of 3 (three) cylinders and an engine displacement of maximum 1000cc. Transmission and rear axle can be replaced but they must come from a garden tractor. There are also components of walk-behind tractors will be accepted (in case of doubt the driver has to show a manufacturers certificate).
3. It is allowed to apply changes to drive shafts and axles to avoid damage.
4. Differential locks are not allowed.
5. No welding or modifications to the engine block or cylinder head are allowed. The combustion chamber bottom edge must remain in original.
6. No homemade intake ports, carburetor distance tubes or resonance tubes are allowed.
7. Carburetor must be in original, without any changes or polishing. Choke may be removed. The diameter of an air restrictor must not be enlarged.
8. Top of the cylinder head must remain in the original.
9. All engines must have a speed limiter. The maximum speed must not be higher then the manufacturer's original instructions with an absolute maximum of 4000rpm. (manufacturer ID required) Changes to the fuel injection pump are not allowed.
10. Intake ports may not be modified, grinded or polished. Intake ducts must remain as in the cast.
11. Flywheel must be the original part. No welding or mechanical modifications to cast flywheels.
12. Maximum tyre size is limited to 23 x 10.5 x 12, or maximum width of 270mm and maximum diameter of 590mm.
13. Changes on frame are allowed to use a not OEM engine. The rest of the tractor must stay in original.
14. Only gasoline or diesel fuel allowed.
15. The maximum length from the centre of the rear axle to the foremost point (except tow-hitch, see page) must not exceed 2000mm.
16. Only engines with not more than 3 cylinders and/or 25HP are allowed (written confirmation of the manufacturer).
17. The maximum weight of vehicle with driver (competition-ready) must not exceed 350kg.

Chapter 4

500kg Stock

1. The tractor must have been produced commercially in standard and series and must have a cast engine block. Engine and frame must be original and must have the appearance of a garden tractor.
2. It is allowed to change the engine, but the engine power must not exceed 25HP, with a maximum of 3 (three) cylinders and an engine displacement of maximum 1000cc. Transmission and rear axle can be replaced but they must come from a garden tractor. There are also components of walk-behind tractors will be accepted (in case of doubt the driver has to show a manufacturers certificate).
3. It is allowed to apply changes to drive shafts and axles to avoid damage.
4. Differential locks are not allowed.
5. No welding or modifications to the engine block or cylinder head are allowed. The combustion chamber bottom edge must remain in original.
6. No homemade intake ports, carburetor distance tubes or resonance tubes are allowed.
7. Carburetor must be in original, without any changes or polishing. Choke may be removed. The diameter of an air restrictor must not be enlarged.
8. Top of the cylinder head must remain in the original.
9. All engines must have a speed limiter. The maximum speed must not be higher then the manufacturer's original instructions with an absolute maximum of 4000rpm.. (manufacturer ID required) Changes to the fuel injection pump are not allowed.
10. Intake ports may not be modified, grinded or polished. Intake ducts must remain as in the cast.
11. Flywheel must be the original part. No welding or mechanical modifications to cast flywheels.
12. Maximum tyre size is limited to 26 x 12 x 12, or maximum width of 310mm and maximum diameter of 670mm.
13. Changes on frame are allowed to use a not OEM engine. The rest of the tractor must stay in original.
14. Only gasoline or diesel fuel allowed.
15. The maximum length from the centre of the rear axle to the foremost point (except tow-hitch, see page) must not exceed 2000mm.
16. Only engines with not more than 3 cylinders and/or 25HP are allowed (written confirmation of the manufacturer).
17. The maximum weight of vehicle with driver (competition-ready) must not exceed 500kg.

Chapter 5

Modified 500kg

General

1. There are only piston engines allowed. It is allowed to use more than one engine, with a maximum sum of 4 cylinders and 1.300cm³. If a one-cylinder-engine is used, there is no limit for the engine displacement. (rotary engines not allowed)
2. No chargers are allowed on engines with more than one cylinder running on petrol. Petrol engines with only one cylinder may be charged with a maximum of one turbocharger. Diesel engines may be charged with a maximum of two turbochargers.
3. Legal fuels are alcohol, diesel, and petrol.
4. Maximum tyre size is 26 x 12.00 x 12, or maximum width of 310mm and maximum diameter of 670mm.
5. The maximum weight of vehicle with driver (ready to compete) must not exceed 500kg.

Chassis

1. The frame must be one piece between the front of the tractor and the rear axle housing mounting bolts.
2. The maximum length from the centre of the rear axle to the foremost point (except tow-eye) must not exceed 2000mm.
3. The front wheels must track with the rear wheels.

Clutches / Flywheels / Transmission

1. The use of automatic transmissions is not permitted
2. By using of automotive engines, the OEM flywheel and clutch bell housing must be protected with a steel protector (3mm) surrounding 360° additionally. The protection must be so wide that it covers the clutch and flywheel.
3. Snowmobile clutches (multi-disc-clutches) must be protected with a steel protector (1,5mm) surrounding 360°. The protection must be wider than the clutch and must be mounted firmly. The protection must be integrated into the belt cover.
4. Drive chains should be shielded with steel (1.5mm) or aluminium (3mm) and must be wider than the chain. It should be mounted properly.

Pulleys

1. No stamped/pressed steel pulleys or not manufacturer-welded pulleys are allowed.
2. If starter pulleys or a starter drive are mounted on the open end of the crankshaft, it must be fixed by an axially screwed restraint system to the crankshaft to prevent that the pulley or drive can detach.

Shielding

1. Engines must be shielded on both sides with steel or aluminium with a minimum thickness of 2 mm. The shielding must extend the complete length of block and in

the height from the top dead centre of the piston to the lowest point of the crankshaft and must not be fitted to the engine.

2. All rotating masses on the crankshaft of motorcycle engines must be shielded with aluminium 6mm or steel 3mm. The shielding must be mounted on the engine block or frame. The gap between rotating mass and shielding may not exceed 12mm.

Aircraft, marine and industrial engines:

1. On aircraft, marine and industrial engines the flywheel, clutch and torque converters may not turn faster than the crankshaft speed.

Roll Over Protection:

1. A rollover protection is mandatory in the 500kg modified class and has to be made of seamless pipe. For details see chapter 8 (page 25).

Chapter 6

Compact Diesel

Chassis

1. The frame must be one piece between the front of the tractor and the rear axle housing mounting bolts.
2. The front wheels must be in track with the rear wheels.
3. The following measurements shall not be exceeded:
 - wheelbase: 1620mm.
 - distance between the centre of the rear axle and the front of the tractor: 2000mm (tow hook not included)
 - maximum width: 1450mm.
 - maximum width of the frame: 420mm. (gain bend on the outside up to 15-30mm is allowed)
 - recommended free space under machine to ground 100mm.
 - maximum width of the hood: 510mm including any side shielding but must be in proportion of the original make and model.

Frame/ shielding.

1. The Tractor must have hood, grill and fenders as intended by the original manufacturer on smaller scale, tractor must retain in stock appearance.
2. The centre of the front axle may not be placed in front of the grill, only when copied stock model has it like that
3. The engine must be shielded on both sides with 1.5mm steel or 2mm aluminium. The shielding must extend the complete length of the engine block and in the height from the top dead centre of the piston until 50mm below the centre of the crankshaft and must not be fitted to the engine. The chassis may be used as part of the shielding. If the hood meets the shielding criteria it may be used as shielding to.
4. All belts and roller chains must be shielded radially with a minimum of 1.5mm steel or 2mm aluminium if the hood does not cover those parts or does not meet the shielding criteria, the shielding must be wider than the belt or chain.

Engine

1. Engine displacement is limited to a maximum of 2500cm³
2. Compact diesel tractors are limited to 4 (four) cylinder engines and 2 (two) valves per cylinder.
3. Maximum of 1 step inlet boost with use of maximum 1 (one) turbocharger.
4. Legal fuel is only diesel fuel, water injection and/or intercooler are allowed.
5. Compact diesels may have one fuel pump of any size.
6. Conversions from 4-stroke into 2-stroke principle is not allowed.

7. The engine must be fastened properly to the chassis with at least 2 engine brackets on the front and 2 on the back, if a gearbox is used this also has to be supported properly.

Tyres

1. Contests open to pulling vehicles with rubber tyres. No four wheel drive allowed.
2. No dual tyres, tyre studs or chains permitted through the wheels.
3. Max tyre size: 800mm diameter and 400mm wide outside tread. Dick Cepek tyres in the size 31x15.50-15 are allowed.

Clutches / Flywheels / Transmission

1. The use of automatic transmissions is not permitted.
2. All clutch/flywheel parts must be ETPC approved. The manufacturer must be on the list of the ETPC Safety Program.
3. In case of a home made version the following rules apply
 - All home made clutches and flywheels must be made of steel plate or billet steel (no cast parts)
 - Drawings with measurements of all home made major components (flywheel, friction disks, floater plates, pressure plates and pressure plates cover) and certificates proving the material specifications must always be with the pulling vehicle and be shown upon tech-com inspectors request
 - Flywheel, pressure plate and pressure plate cover are allowed out of aluminium, only wrought (billet) aluminium is adequate for pulling applications if mechanical properties are acceptable
 - minimum mechanical properties (steel and aluminium)
 - tensile strength 414 N/mm².
 - yield strength 275 N/mm².
 - No part of the clutch may rotate faster than the engine speed

Bellhousing

1. Bellhousing has to be ETPC approved. The manufacturer must be on the list of the ETPC Safety Program
2. In case of a home made version the following rules apply
 - The bellhousing has to be at least 6mm thick seamless steel tube around the clutch/flywheel and at least 3mm steel or 4mm aluminum at the front and rear side.
 - The bellhousing has to smooth and free of obstacles on the inside.
 - Bellhousing must be properly attached to the engine.
 - No welding in the rotation area allowed except for a starter pocket, and/or one weld at the bottom, if the bellhousing is made of sheet metal the weld at the

bottom has to be accompanied by a Roentgen, ultrasound or Magna-flux welding report which must be shown upon tech-com inspectors request.

- In case of a welded bellhousing out of sheet metal the use of a liner is mandatory, the liner has to be at least 2mm Stainless steel and should cover the complete straight inner side and has to be fixed with 1 (one) M6 bolt at the bottom of the bellhousing. When the bellhousing is made of seamless pipe the liner is still recommended but not mandatory.

Driveline shielding

1. Driveline should be guarded with 5mm steel or 6mm aluminium, the shielding should be round and max. 50mm wider than the biggest part of the driveline.
2. The use of cross links and/or homokinetic couplings is not allowed.
3. Driveline brakes and price-as brakes are allowed in combination with rear wheel brakes, should be covered 360° with a minimum of 10mm steel and in the front and back side with min. of 3mm steel

RPM regulation

1. All diesel engines must have a spring on the fuel pump so the pump returns automatically to shut-off/idle position when you go of throttle.

RPM restriction

1. The flywheel and clutch may not turn faster the crankshaft speed.

Firewall

1. A firewall between engine compartment and driver is mandatory. The firewall should be from side to side and from top driveline or bellhousing (depending on it's position) to the top of the hood. The firewall should be made of minimal 2mm aluminium (stainless steel strongly suggested)and may not be mounted directly to the engine.

Fuel tanks and fuel lines

1. All compact diesel tractors should have a fuel shut-off on a easy to reach place on the low pressure side of the fuel system, in case of an automatic system the valve has to be fail-save.

Rollover protection

2. A rollover protection is mandatory in the compact diesel class and has to be made of seamless pipe. For details see chapter 8 (page 25).

Chapter 7

Modified 600kg

Chassis

1. The frame must be one piece between the front of the tractor and the rear axle housing mounting bolts.
2. The front wheels must be in track with the rear wheels.
3. The following measurements shall not be exceeded:
 - distance between the centre of the rear axle and the front end of the tractor: 2440mm (tow hook not included)
 - maximum width: 1600mm.

Frame/ shielding.

1. The engine must be shielded on both sides with 1.5mm steel or 2mm aluminium. The shielding must extend the complete length of block and in the height from the top dead centre of the piston until 50mm below the centre of the crankshaft and must not be fitted to the engine. The chassis may be used as part of the shielding.
2. All belts and roller chains must be shielded radially with a minimum of 1.5mm steel or 2mm aluminium, the shielding must be wider than the belt or chain.

Engine

1. Engine ranking system, maximum 100 points:
 - 20 points per 1000cc. (*It is allowed to split points 100cc = 2 Points.*)
 - 40 points per turbo.
 - 50 points for mechanical driven charging system.
2. Only gasoline, diesel and alcohol are allowed. The use of oxygen or nitrogen is prohibited, water injection is allowed.
3. Engines must be fastened properly to the chassis with at least 2 engine brackets on the front and 2 on the back, if a gearbox is used this also has to be supported properly.

Tyres

1. Contests open to pulling vehicles with rubber tyres. No four wheel drive allowed.
2. No dual tyres, tyre studs or chains permitted through the wheels.
3. Max tyre size: 800mm diameter and 400mm wide outside tread. Dick Cepek tyres in the size 31x15.50-15 are allowed.

Clutches / Flywheels / Transmission

1. The use of automatic transmissions is not permitted.
2. All clutch/flywheel parts must be ETPC approved. The manufacturer must be on the list of the ETPC Safety Program.
3. In case of a home made version the following rules apply
 - All home made clutches and flywheels must be made of steel plate or billet steel (no cast parts)

- Drawings with measurements of all home made major components (flywheel, friction disks, floater plates, pressure plates and pressure plates cover) and certificates proving the material specifications must always be with the pulling vehicle and be shown upon tech-com inspectors request
- Flywheel, pressure plate and pressure plate cover are allowed out of aluminium, only wrought (billet) aluminium is adequate for pulling applications if mechanical properties are acceptable
- minimum mechanical properties (steel and aluminium)
 - tensile strength 414 N/mm².
 - yield strength 275 N/mm².
- No part of the clutch may rotate faster then the engine speed

Bellhousing

1. Bellhousing has to be ETPC approved. The manufacturer must be on the list of the ETPC Safety Program
2. In case of a home made version the following rules apply
 - The bellhousing has to be at least 6mm thick seamless steel tube around the clutch/flywheel and at least 3mm steel or 4mm aluminum at the front and rear side.
 - The bellhousing has to smooth and free of obstacles on the inside
 - Bellhousing must be properly attached to the engine.
 - No welding in the rotation area allowed except for a starter pocket, and/or one weld at the bottom if the bellhousing is made of sheet metal, the weld at the bottom has to be accompanied by a Roentgen, ultrasound or Magna-flux welding report which must be shown upon tech-com inspectors request.
 - In case of a welded bellhousing out of sheet metal the use of a liner is mandatory, the liner has to be at least 2mm Stainless steel and should cover the complete straight inner side and has to be fixed with 1 (one) M6 bolt at the bottom of the bellhousing. When the bellhousing is made of seamless pipe the liner is still recommended but not mandatory.

Driveline shielding

1. Driveline should be guarded with 5mm steel or 6mm aluminium, the shielding should be round and max. 50mm wider than the biggest part of the driveline.
2. The use of cross links and/or homokinetic couplings is not allowed.
3. Driveline brakes and price-as brakes are allowed in combination with rear wheel brakes, should be covered 360° with a minimum of 10mm steel and in the front and back side with min. of 3mm steel

RPM regulation

1. All engines must have 2 springs on the throttle mounted independently of each other to force automatically to shut-off/idle position when you go off the throttle.

RPM restriction

1. The flywheel and clutch may not turn faster the crankshaft speed.

Fuel tanks and fuel lines

1. All Modified tractors should have a fuel shut-off on a easy to reach place on the low pressure side of the fuel system, in case of an automatic system the valve has to be fail-save.

Rollover protection

1. A rollover protection is mandatory in the 600kg Modified class and has to be made of seamless pipe. For details see chapter 8 (page 25).

Chapter 8

Roll Over Protection

General

1. The Driver Rollover Protection (ROP) has been designed in cooperation with specialists in order to protect the driver in case of the vehicle tipped over during a pulling competition.
2. The design or ROP built according to the given specifications are not to be understood as an automatic guarantee for providing the driver for any risks.
3. These specifications must be seen as a set of minimum requirements and advisory guidelines.
4. Neither the EGPC Board, the T&S Board nor any of their members can be made responsible for consequences resulting from the application of the ROP specifications or malfunctions of the safety devices in question.
5. The ROP may tilt a maximum of 20° to the horizontal ground surface.
6. The use of aluminium for the ROP is NOT allowed.
7. tubes must be one piece from side to side and may not contain Welds. (meaning all corners have to be bend and not made by welding arcs)
8. Welds must be untouched. (grinding is not allowed)

Design examples:

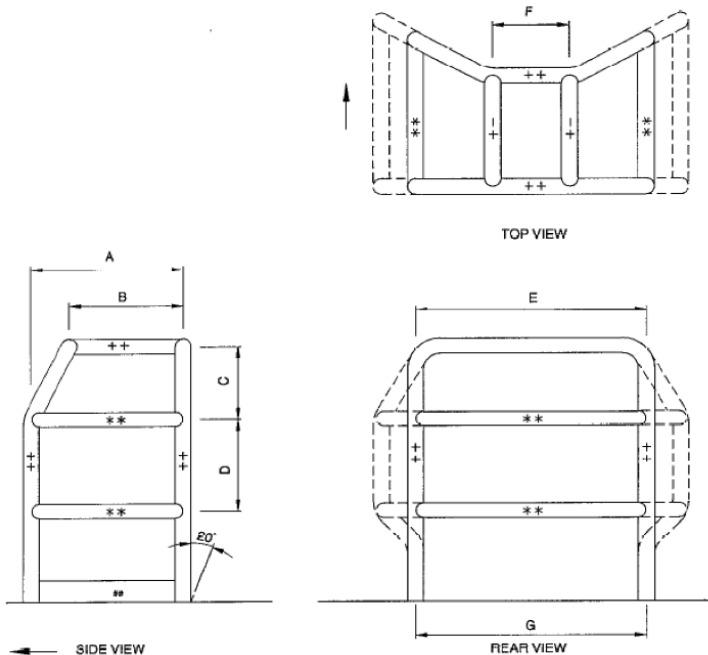

	construction steel	CrMo or Docol steel
500kg Modified	outer diameter x wall thickness (minimum)	outer diameter x wall thickness (minimum)
tube "++"	Ø27 x 2,35 mm (3/4")	Ø25 x 2,0 mm
tube "※※"	Ø22 x 2,0 mm (1/2")	Ø20 x 2,0 mm

	construction steel	CrMo or Docol steel
Compact Diesel and 600kg Modified	outer diameter x wall thickness (minimum)	outer diameter x wall thickness (minimum)
tube "++"	Ø34 x 2,5 mm (1")	Ø35 x 2,0 mm
tube "※※"	Ø27 x 2,35 mm (3/4")	Ø25 x 2,0 mm

##	support strip Ø50 x 4 mm; has to be welded between both sides of the ends of the vertical tubes
A	minimum 300mm centre to centre
B	minimum 300mm centre to centre
C	maximum 200mm
D	maximum 250mm
E	upper part must have minimal 50mm and maximum 200mm horizontal and vertical space to the drivers helmet to prevent neck injury
F	recommendation 200mm
G	Centerline of tubes may not be wider then max. chassis width.

#NOTE: tube sizes for imperial (like 3/4") are rounded up and can differ from different manufacturers but should be within a 2% tolerance...

Mounting examples:

channel chassis:

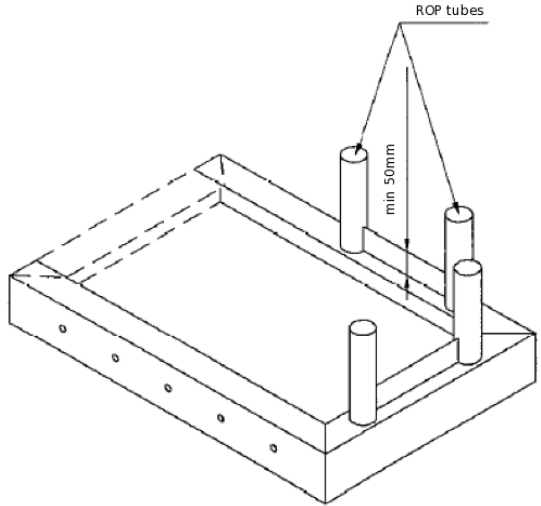
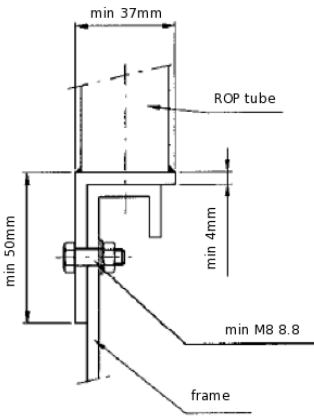

- The vertical tubes can be welded directly on an angle bar of at least 37x50x4mm
- Mounting to the frame must happen with on both sides at least 4xM10 or 6xM8 8.8 bolts
- Support strip of minimal 50x4mm has to be welded between the vertical tubes on the angle bar

tube chassis by welding:

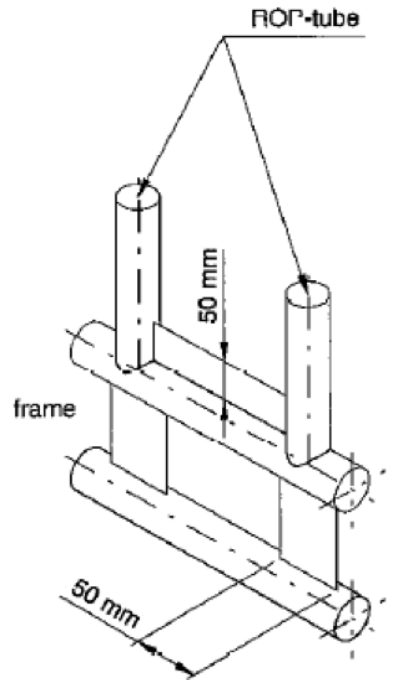
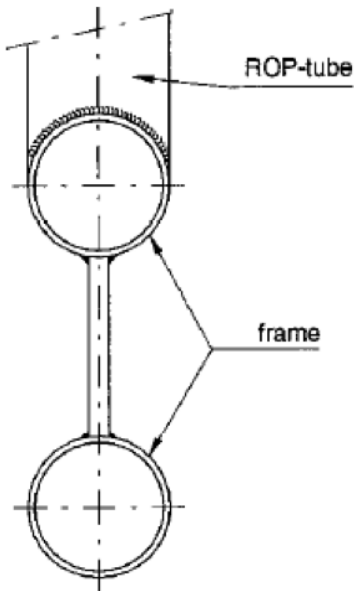

- Directly under the horizontal frame tube and in line with the vertical ROP tubes support strips should be welded of at least 50x4mm
- Support strip of minimal 50x4mm has to be welded between the vertical tubes on the top chassis tube.

tube chassis by bolting:

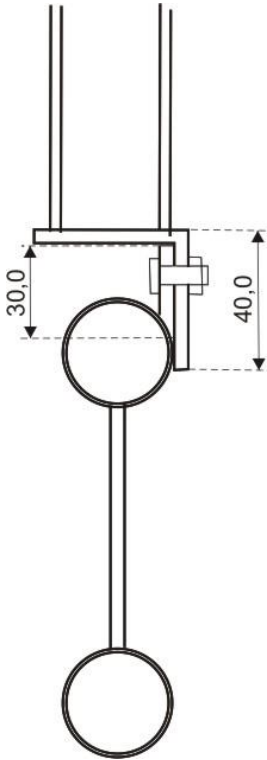

- The vertical tubes can be welded directly on an angle bar of at least 37x50x4mm
- Mounting to the frame must happen with on both sides at least 4xM10 or 6xM8 8.8 bolts
- Support strip of minimal 50x4mm has to be welded between the vertical tubes on the angle bar
- Directly under the horizontal frame tube and in-line with the vertical ROP tubes support strips should be welded of at least 50x4mm.

square tube chassis by bolting:

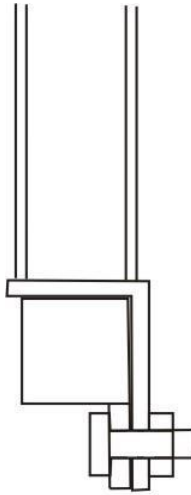

- The vertical tubes can be welded directly on an angle bar of at least 37x50x4mm
- Mounting to the frame must happen with on both sides at least 4xM10 or 6xM8 8.8 bolts
- Support strip of minimal 50x4mm has to be welded between the vertical tubes on the angle bar
- Directly under the horizontal frame tube and in-line with the vertical ROP tubes support strips should be welded of at least 50x4mm.

Example connection for removable ROP:

- The connection piece must be at least 300mm. long with a minimal wall thickness of 3mm.
- One side of the connection piece must be welded to the tube.
- The connection piece may be placed inside or outside the ROP tube.
- Every tube must have 2 M8 8.8 bolts and must have a tight fit in the holes.

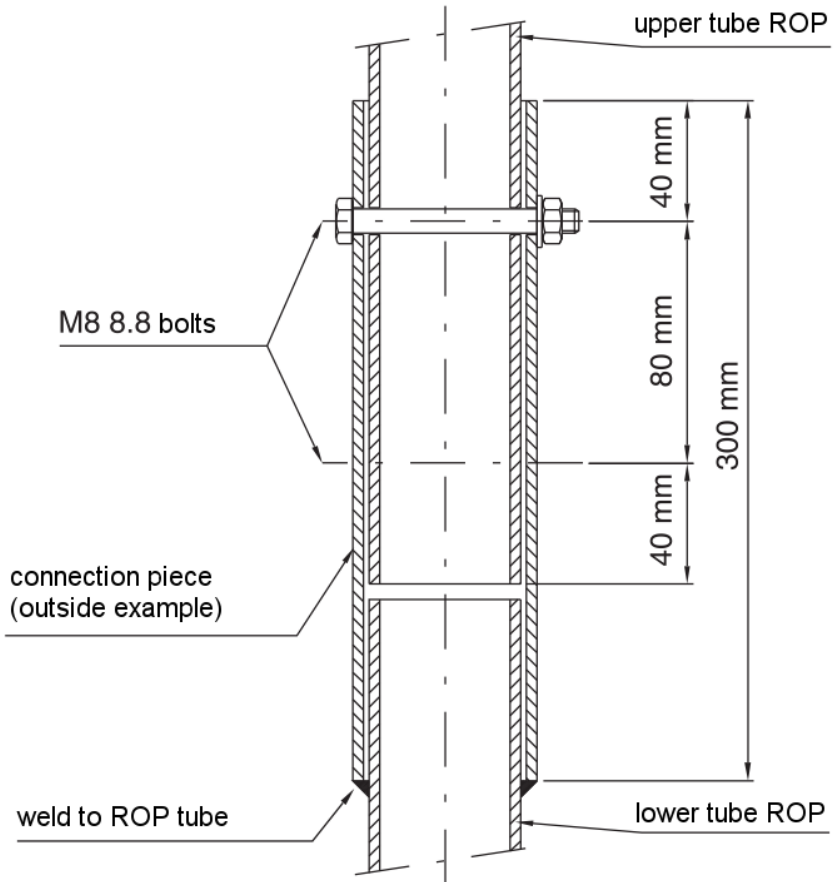

- Bolts may be placed in either upper or lower tube.

Chapter 9

Operation of Contest

Safety

1. If track officials and/or Tech inspectors feel a vehicle is unsafe they have the right not to allow the vehicle to pull.
2. Approved full-face helmets are mandatory. All drivers in all divisions must wear helmets with chin strap fastened and screen closed when pulling.
3. Wearing a safety belt is mandatory (in the classes 500kg Modified, 600kg Compact Diesel and 600kg Modified) and has to be at least a 4-point type.
4. The safety belt has to be attached with all points to the ROP (Roll Over Protection).
5. The use of a fire suit (including gloves, socks, head-socks, leather shoes) is mandatory for all drivers in the classes 500kg Modified, 600kg Compact Diesel and 600kg Modified. Fire suits must meet the following requirements;
 - A minimum of one layer fire suit of Nomex 3 or equivalent.
 - The maximum age of a Nomex fire suit is six (6) years, of other suits two(2) years, in cases of doubt it is the competitor's duty to prove the age of the suit.
 - Suits must have the possibility to tie collar, sleeves and legs. If leather boots are used fire proof socks are not mandatory.